

Synthesis and Reactivity of Binuclear Pyrazolate-bridged Ruthenium(I) Complexes. Crystal Structures of Bis[μ -(3,5-dimethylpyrazolato-*NN'*)-tricarbonylruthenium(I)] (*Ru-Ru*) and Bis[μ -(3,5-dimethylpyrazolato-*NN'*)]- μ -iodo-bis[tricarbonylruthenium(II)] Tri-iodide[†]

Javier A. Cabeza, Cayetana Landázuri, and Luis A. Oro*

Departamento de Química Inorgánica, Instituto de Ciencia de Materiales de Aragón, Universidad de Zaragoza-CSIC, 50009 Zaragoza, Spain

Daniele Belletti, Antonio Tiripicchio,* and Marisa Tiripicchio Camellini

Istituti di Chimica Generale ed Inorganica e di Strutturistica Chimica, Università di Parma, Centro di Studio per la Strutturistica Diffattometrica del CNR, Viale delle Scienze, 43100 Parma, Italy

The complexes $[\text{Ru}_2(\mu\text{-L})_2(\text{CO})_6]$ [HL = 3,5-dimethylpyrazole (Hdmpz) (**1**), pyrazole (Hpz) (**2**), 3-methylpyrazole (**3**), or indazole (**4**)] have been obtained by reaction of $\text{RuCl}_3 \cdot n\text{H}_2\text{O}$ with carbon monoxide in refluxing 2-methoxyethanol followed by reduction with zinc in the presence of HL and CO. This synthetic route provides an easy method to prepare ruthenium(I) compounds in high yield. Complexes (**1**) and (**2**) react with iodine to afford $[\text{Ru}_2(\mu\text{-I})(\mu\text{-L})_2(\text{CO})_6]\text{I}_3$ [L = dmpz (**5**) or pz (**6**)] or $[\text{Ru}_2(\mu\text{-L})_2(\text{CO})_6]$ [L = dmpz (**7**) or pz (**8**)] depending on the Ru:I ratio used. Complex (**1**) reacts with an excess of acetonitrile at 56 °C to give the C_1 monosubstituted product $[\text{Ru}_2(\mu\text{-dmpz})_2(\text{CO})_5(\text{NCMe})]$ (**9**), whereas with excess of pyridine (py) it affords the C_s monosubstituted product $[\text{Ru}_2(\mu\text{-dmpz})_2(\text{CO})_5(\text{py})]$ (**10**). However, it reacts with an excess of PPh_3 , $\text{P}(\text{C}_6\text{H}_{11})_3$, or bis(diphenylphosphino)methane (dppm) at 20 °C to give the C_1 monosubstituted products $[\text{Ru}_2(\mu\text{-dmpz})_2(\text{CO})_5(\text{PR}_3)]$ [$\text{PR}_3 = \text{PPh}_3$ (**11**), $\text{P}(\text{C}_6\text{H}_{11})_3$ (**12**), or dppm (**13**)]. Infrared and ^1H and $^{31}\text{P}\{-^1\text{H}\}$ n.m.r. spectra of all the compounds are presented and discussed in relation to their structures. The crystal structures of complexes (**1**) and (**5**) have been determined by X-ray diffraction methods. Crystals of (**1**) are monoclinic, space group $P2_1/n$, with $a = 15.388(7)$, $b = 10.497(5)$, $c = 13.706(5)$ Å, $\beta = 110.32(2)^\circ$, and $Z = 4$. Crystals of (**5**) are triclinic, space group $P\bar{1}$, with $a = 10.970(5)$, $b = 12.393(6)$, $c = 10.522(6)$ Å, $\alpha = 98.22(2)^\circ$, $\beta = 103.94(3)^\circ$, $\gamma = 74.29(2)^\circ$, and $Z = 2$. The structures were solved from diffractometer data by Patterson and Fourier methods and refined by full-matrix least squares to $R = 0.056$ (**1**) and 0.043 (**5**) for 1 987 (**1**) and 3 348 (**5**) observed reflections. In complex (**1**) the two Ru atoms are doubly bridged by two dmpz ligands with a Ru-Ru distance, 2.705(2) Å, consistent with a metal-metal bond. In (**5**) an iodine atom has been inserted between the two Ru atoms, Ru-I 2.699(2) and 2.707(2) Å, and the Ru-Ru distance is increased to 3.636(2) Å.

The chemistry of rhodium and iridium complexes containing pyrazolate ligands (pz) has attracted much attention during the last few years.^{1,2} These studies have revealed that pyrazolates have the ability to act as strongly bound yet flexible bridging ligands capable of maintaining two metal fragments in close proximity, both within and beyond the requirements of metal-metal interactions.

On the other hand, although the first ruthenium(I) compound $[\text{Ru}_2(\text{cp})_2(\text{CO})_4]$ (cp = $\eta\text{-C}_5\text{H}_5$) was reported some 25 years ago,³ relatively few complexes with ruthenium in this oxidation state have appeared,^{4,5} probably due to the non-availability of a good general synthetic method. Apart from $[\text{Ru}_2(\text{cp})_2(\text{CO})_4]$,⁶ $[\text{Ru}_4\text{H}_4(\text{CO})_{12}]$,⁷ and carboxylate complexes of the type $[\text{Ru}_2(\mu\text{-RCO}_2)_2(\text{CO})_4\text{L}_2]$ ⁸⁻¹⁰ whose syntheses are well established, most of the other known ruthenium(I) compounds have been obtained in low yields, generally as by-products of reactions of $[\text{Ru}_3(\text{CO})_{12}]$ or other polynuclear clusters,^{4,11} or have been made using sophisticated ligands, as for the complexes $[\text{Ru}_2(\mu\text{-Cl})_2(\text{CO})_4(\text{PR}_3)_2]$ which can be obtained only by using phosphines containing at least two *t*-butyl groups.¹² It is also interesting that some binuclear ruthenium(I) complexes have been postulated as intermediates in homo-

geneously catalysed reactions,¹³ and are catalytic precursors for the carbonylation of amines,¹⁴ the hydrogenation of carboxylic acids,^{10a} and the addition of acetic acid to alkynes.¹⁵

In view of these data, we decided to investigate the preparation of new ruthenium(I) complexes containing the $\text{Ru}_2(\mu\text{-pz})_2$ framework. Furthermore, there are very few pyrazolate complexes of ruthenium,¹⁶⁻¹⁸ and none at all of ruthenium(I). In this article we report the synthesis of complexes of the type $[\text{Ru}_2(\mu\text{-pz})_2(\text{CO})_6]$, starting from $\text{RuCl}_3 \cdot n\text{H}_2\text{O}$, the cheapest starting material for ruthenium compounds, and on their reactivity towards oxidizing reagents and nitrogen- and phosphorus-donor ligands. We also present the X-ray structure determinations of $[\text{Ru}_2(\mu\text{-dmpz})_2(\text{CO})_6]$ (**1**) and $[\text{Ru}_2(\mu\text{-I})(\mu\text{-dmpz})_2(\text{CO})_6]\text{I}_3$ (**5**) (Hdmpz = 3,5-dimethylpyrazole). Part of this work has been communicated in a preliminary form.¹⁹

Results and Discussion

Complexes of the Type $[\text{Ru}_2(\mu\text{-L})_2(\text{CO})_6]$ (L = a pyrazolate ligand).—It has been reported that the yellow solution prepared by treating $\text{RuCl}_3 \cdot n\text{H}_2\text{O}$ with carbon monoxide in refluxing 2-methoxyethanol is a useful source of mononuclear ruthenium(II) carbonyl compounds,^{4,5,20} and that zinc reduction under carbon monoxide of that solution mixture of chlorocarbonyl

[†] Supplementary data available: see Instructions for Authors, *J. Chem. Soc., Dalton Trans.*, 1989; Issue 1, pp. xvii—xx.

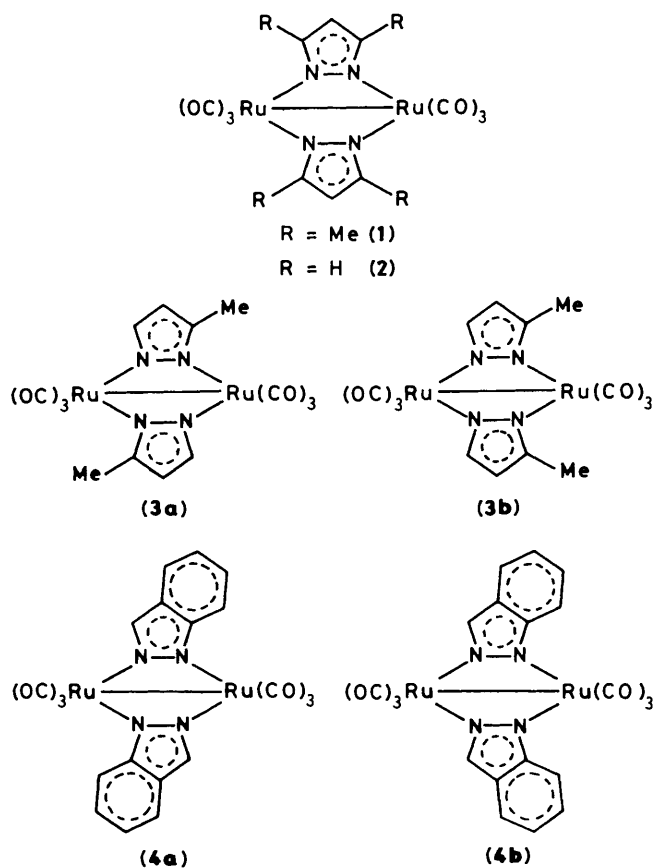

species produces $[Ru_3(CO)_{12}]$.²¹ Interestingly, when the zinc reduction of the yellow solution is carried out in the presence of carbon monoxide and pyrazole-type ligands, the expected ruthenium(I) intermediates can be trapped. Thus, we obtained medium to excellent yields of the white or pale yellow, air-stable, ruthenium(I) complexes (1)–(4). They do not lose carbon monoxide (even under vacuum), in contrast to the analogous carboxylate complexes $[Ru_2(\mu-RCO_2)_2(CO)_6]$ ($R = \text{alkyl}$) which undergo spontaneous decarbonylation to give polymeric $[\{Ru_2(\mu-RCO_2)_2(CO)_4\}_n]$,⁸ they do not react with water either, as do the benzoate complexes $[Ru_2(\mu-RC_6H_4CO_2)_2(CO)_6]$ which give $[Ru_2(\mu-RC_6H_4CO_2)_2(CO)_5(H_2O)]$.⁹

These complexes were characterized by microanalysis, molecular weight measurements (Table 1), and ¹H n.m.r. and i.r. spectroscopies (Table 2). The fast-atom bombardment (f.a.b.) mass spectrum of complex (1) shows the molecular ion at m/z 560 (20%, ¹⁰¹Ru), and the successive loss of six CO ligands. The ¹H n.m.r. spectra of the complexes (1)–(4) are as expected, those of (3) and (4) showing the presence of the two possible isomers (a) and (b). The X-ray structure determination of complex (1), discussed below, confirms the proposed structure, which is related to that of the osmium carboxylate complex $[Os_2(\mu-MeCO_2)_2(CO)_6]$.²²

We also explored the reaction of $[Ru_3(CO)_{12}]$ with various amounts of pyrazole-type ligands, but only in the case of 3,5-dimethylpyrazole, and using a 1:3 mol ratio, did we obtain a complex of the type $[Ru_2(\mu-dmpz)_2(CO)_6]$ in high yield (80% after column chromatography). When other pyrazoles (HL = pyrazole, 3-methylpyrazole, or indazole) were used, mixtures of $[Ru_3(CO)_{12}]$, $[Ru_4H_4(CO)_{12}]$, $[Ru_3(\mu-H)(\mu-L)(CO)_{10}]$, and $[Ru_2(\mu-L)_2(CO)_6]$ were recognized by i.r. and ¹H n.m.r. spectra, but they were not separated.

Very recently, Bruce *et al.*²³ reported that the reactions of

Table 1. Analytical data and molecular weights

| Compound | Microanalysis ^a (%) | | | $M^{a,b}$ / g mol ⁻¹ |
|----------|--------------------------------|--------------|----------------|------------------------------------|
| | C | H | N | |
| (1) | 34.4 (34.3) | 2.6 (2.5) | 10.1 (10.0) | 560 (560.5) |
| (2) | 28.9 (28.9) | 1.1 (1.2) | 11.1 (11.1) | 501 (504.4) |
| (3) | 31.7 (31.6) | 2.1 (1.9) | 10.9 (10.5) | 531 (532.5) |
| (4) | 39.8 (39.7) | 1.9 (1.7) | 9.4 (9.3) | 589 (604.5) |
| (5) | 15.2 (16.1) | 1.1 (1.2) | 4.7 (4.7) | |
| (6) | 14.4 (14.2) | 0.4 (0.6) | 5.6 (5.5) | |
| (7) | 23.2 (23.6) | 2.0 (1.7) | 6.6 (6.9) | 801 (814.3) |
| (8) | 18.4 (19.0) | 0.9 (0.8) | 7.2 (7.4) | 734 (758.2) |
| (9) | 35.3 (35.6) | 2.8 (3.0) | 11.7 (12.2) | |
| (10) | 39.0 (39.3) | 3.5 (3.1) | 11.1 (11.5) | |
| (11) | 49.7 (49.9) | 3.9 (3.6) | 6.9 (7.0) | |
| (12) | 48.2 (48.7) | 6.1 (5.8) | 7.0 (6.9) | |
| (13) | 52.7 (52.4) | 4.1 (3.9) | 5.8 (6.1) | |

^a Calculated values in parentheses. ^b Osmometrically in chloroform.

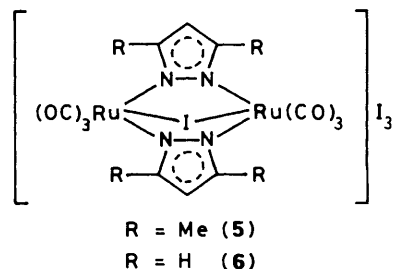

$[Ru_3(CO)_{12}]$ with HL = 3,5-dimethylpyrazole or pyrazole in 1:1 mol ratios afford the trinuclear clusters $[Ru_3(\mu-H)(\mu-L)(CO)_{10}]$ in low yields, but they do not mention any binuclear compound.

Oxidative-addition Reactions.—To study the reactivity of these binuclear compounds we chose complex (1), and also (2), because they were obtained in high yields and they do not present isomers. Thus, treatment of hexane solutions of complex (1) or (2) with iodine led to immediate precipitation of the very insoluble complexes $[Ru_2(\mu-I)(\mu-L)_2(CO)_6]I_3$ [$L = \text{dmpz}$ (5) or pz (6)], regardless of the amount of iodine used. When the ratio Ru:I₂ was > 1:1, the isolated yields (based on iodine) of complexes (5) and (6) were quantitative, with the excess of the starting ruthenium compound remaining in solution. However, when the reactions were carried out in dichloromethane with a Ru:I₂ ratio of 2:1, monitoring of the reactions by i.r. spectroscopy indicated that half of the starting ruthenium compounds was instantaneously consumed to form (5) or (6), but the reactions progressed further, albeit slowly, to give finally and quantitatively the neutral complexes $[Ru_2I_2(\mu-L)_2(CO)_6]$ [$L = \text{dmpz}$ (7) or pz (8)]. Using an excess of iodine the only products observed were of the type $[Ru_2(\mu-I)(\mu-L)_2(CO)_6]I_3$.

Table 2. I.r. and ^1H and ^{31}P - $\{^1\text{H}\}$ n.m.r. data

| Compound | $\nu(\text{CO})^a/\text{cm}^{-1}$ | ^1H N.m.r. $^b(\delta)$ |
|-------------------|--|---|
| (1) | 2 089m, 2 057s, 2 013vs, 1 998m, 1 971w, 1 964w ^c | 5.60 (s, 1 H), 2.10 (s, 6 H) |
| (2) | 2 094m, 2 063s, 2 018vs, 2 005m, 1 982w, 1 969w ^c | 7.19 (d, J 2.1, 2 H), 6.07 (t, J 2.1, 1 H) |
| (3a) + (3b) | 2 091m, 2 059s, 2 015vs, 2 001m, 1 982w, 1 966w ^c | 7.10 (d, J 1.9, 1 H), 7.08 (d, J 1.9, 1 H), 5.76 (apparent t, J 1.9, 2 H), 2.10 (s, 6 H) ^d |
| (4a) + (4b) | 2 094m, 2 065s, 2 019vs, 2 006m, 1 972w, 1 953w ^c | 7.80 (d, J 1.0, 1 H), 7.57 (dt, J 7.6, 1.0, 1 H), 7.53 (dd, J 8.7, 1.0, 1 H), 7.28 (ddd, J 8.7, 7.7, 1.0, 1 H), 7.00 (ddd, J 7.7, 7.6, 1.0, 1 H) ^e |
| (5) | 2 133s, 2 082s, 2 073s, 1 987w | 6.13 (s, 1 H), 2.52 (s, 6 H) |
| (6) | 2 128s, 2 080s, 2 077s, 1 995w | 7.90 (d, J 2.4, 2 H), 6.54 (t, J 2.4, 1 H) |
| (7) ^f | 2 122s, 2 118s, 2 104w, 2 078m, 2 055s, 2 048s, 1 985m, 1 955s, 1 953w | 6.1 (m, br, 1 H), 2.5 (m, br, 6 H) ^d |
| (8a) or (8b) | 2 128s, 2 086m, 2 072s, 2 060s, 1 996m | 8.46 (d, J 2.3, 2 H), 6.54 (t, J 2.3, 1 H) ^d |
| (8c) | 2 128s, 2 086s, 2 072s, 2 060s, 2 001s | 8.31 (d, J 2.1, 1 H), 8.14 (d, J 2.1, 1 H), 6.31 (t, J 2.1, 1 H) ^d |
| (9) | 2 088m, 2 054s, 2 004vs, 1 995s, 1 975w, 1 930w | 5.70 (s, 1 H), 5.56 (s, 1 H), 2.12 (m, 15 H) |
| (10) | 2 068s, 1 997vs, 1 930s | 8.83 (m, 2 H), 7.84 (t, J 7.3, 1 H), 7.38 (t, J 7.3, 2 H), 5.76 (s, 2 H), 2.25 (s, 6 H), 1.54 (s, 6 H) |
| (11) ^g | 2 088m, 2 053s, 2 008vs, 1 992s, 1 977m, 1 950w | 7.30 (m, 15 H, PPh_3), 5.63 (s, 1 H), 5.53 (s, 1 H), 2.15 (s, 3 H), 2.10 (s, 3 H), 2.07 (s, 3 H), 1.53 (s, 3 H) |
| (12) ^h | 2 086m, 2 052s, 2 000vs, 1 984s, 1 964s, 1 953w | 5.64 (s, 1 H), 5.57 (s, 1 H), 2.19 (s, 3 H), 2.15 (s, 3 H), 2.09 (s, 3 H), 2.07 (s, 3 H), 2.2–1.0 [m, vbr, $\text{P}(\text{C}_6\text{H}_{11})_3$] |
| (13) ⁱ | 2 089m, 2 050s, 1 988vs, 1 981s, 1 964vs, 1 935m | 7.23 (m, 20 H, dppm), 5.61 (s, 1 H), 5.47 (s, 1 H), 3.01 (m, 2 H, dppm), 2.10 (s, 3 H), 2.07 (s, 3 H), 2.05 (s, 3 H), 1.53 (s, 3 H) |

^a s = Strong, m = medium, w = weak, and v = very; spectra measured in CH_2Cl_2 unless otherwise stated. ^b s = singlet, d = doublet, t = triplet, and m = multiplet; spectra measured in CDCl_3 unless otherwise stated; coupling constants, J/Hz . ^c In n -hexane. ^d In $(\text{CD}_3)_2\text{CO}$. ^e Only the signals of the major component of the mixture are given since most of those of the minor component are overlapped with them. ^f Mixture of isomers. ^g $\delta(^{31}\text{P})$ 46.0 (s) p.p.m. ^h $\delta(^{31}\text{P})$ 50.3 (s) p.p.m. ⁱ $\delta(^{31}\text{P})$ 41.9 (d, J 40, 1P) and -27.0 p.p.m. (d, J 40 Hz, 1P).

With these data, the reaction scheme shown in equations (1) and (2) for $\text{L} = \text{pz}$ can be proposed.

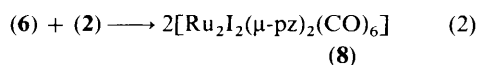
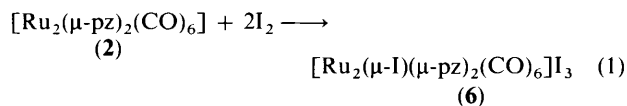

All attempts to exchange the tri-iodide anion in complex (5) for other bulky anions ($[\text{ClO}_4]^-$ or $[\text{BF}_4]^-$) were unsuccessful, mixtures of cationic complexes and the neutral complex (7) being obtained, as indicated by the i.r. spectra of the products.

Compound (5) reacts with Vaska's complex, $[\text{IrCl}(\text{CO})(\text{PPh}_3)_2]$, oxidizing it to $[\text{IrI}_2\text{Cl}(\text{CO})(\text{PPh}_3)_2]$. Thus, when both complexes were mixed in dichloromethane, in a 1:1 ratio, the i.r. spectrum of this solution showed the rapid disappearance of the absorptions of the starting materials and the appearance of bands corresponding to $[\text{IrI}_2\text{Cl}(\text{CO})(\text{PPh}_3)_2]$ and complex (7).

The i.r. spectra of compounds (5) and (6) (Table 2) are nearly identical, indicating that both compounds have the same structure, showing the $\nu(\text{CO})$ absorptions at higher frequencies than those observed for the starting materials, as expected for a higher oxidation state of the metal centre. Their ^1H n.m.r. spectra display the expected peaks for the 3,5-dimethylpyrazolate and pyrazolate ligands, respectively. The f.a.b. mass spectrum of complex (5) shows the parent peak at m/z 687 (100%, ^{101}Ru), corresponding to the species $[\text{Ru}_2(\mu\text{-I})(\mu\text{-dmpz})_2(\text{CO})_6]^+$, and the successive loss of six CO ligands, but it also contains a little peak at m/z 814 (9%) which corresponds to the species $[\text{Ru}_2\text{I}_2(\mu\text{-dmpz})_2(\text{CO})_6]^+$, suggesting that complex (7) is somehow formed within the spectrometer. The structure of complex (5) has been confirmed by an X -ray diffraction study, discussed below.

Products (7) and (8) gave satisfactory microanalyses and molecular weights (osmometrically in chloroform) (Table 1), but they are in fact mixtures of isomers, as indicated by their i.r. and ^1H n.m.r. spectra (Table 2), which show too many peaks for them being single compounds. Product (8) consists of two different isomers, one of which could be isolated pure due to its lower solubility in dichloromethane. The ^1H n.m.r. spectrum of

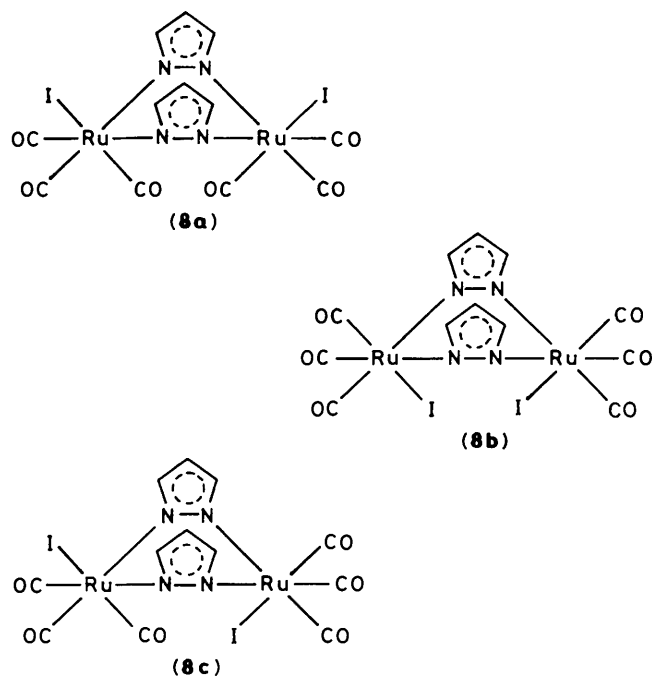

this complex shows a doublet and a triplet for the pyrazolate protons, indicating that it is either (8a) or (8b), which are the two most symmetric isomers possible. However, the ^1H n.m.r. spectrum of the most soluble isomer displays two doublets and one triplet, indicating (8c). Any other isomer would give more signals in the ^1H n.m.r. spectrum.

Curiously, complexes (1) and (2) react slowly with chlorine or bromine in carbon tetrachloride only when the halogen is in a great excess (over ten-fold), affording white or pale yellow solids, whose microanalyses could not be reproduced from one preparation to another. Their i.r. spectra show the $\nu(\text{CO})$ absorptions at higher wavenumbers than those of (1) or (2), suggesting that the metal has oxidized, but the bands are broad and no structural information could be obtained from them. Their insolubility prevented any further analysis.

These results contrast with those reported for the reactions of $[\text{Ru}_2(\mu\text{-Cl})_2(\text{CO})_4(\text{PBu}^t\text{R})_2]$ ($\text{R} = p\text{-tolyl}$ or Bu^t) with chlorine, which lead to the formation of the ruthenium(II) dimers $[\text{Ru}_2\text{Cl}_2(\mu\text{-Cl})_2(\text{CO})_4(\text{PBu}^t\text{R})_2]$ ^{12b,24}

The different reactivity of iodine compared to those of bromine or chlorine towards the dimers (1) and (2) may be explained by their different tendency to form the electrophile X^+ , since studies on the cleavage of metal-metal bonds by halogens in the complexes $[\text{M}_2(\text{cp})_2(\text{CO})_6]$ ($\text{M} = \text{Mo}$ or W^{25}), $[\text{M}_2(\text{cp})_2(\text{CO})_4]$ ($\text{M} = \text{Fe}^{26}$ or Ru^{27}), and $[\text{Mn}_2\{\mu\text{-(EtO)}_2\text{-POP(OEt)}_2\}_2(\text{CO})_6]$ ²⁸ have revealed that the reaction frequently proceeds through halogen-bridged cationic intermediates, their stabilities depending on the nature of the halogen, the metal-ligand fragments, and the reaction conditions [equations (1) and (2)].

The stability of the metal-metal bond in complex (1) is noteworthy: (1) does not react with dihydrogen, $\text{Ag}[\text{BF}_4]$, $\text{Ag}[\text{BF}_4]\text{-PPh}_3$, or $[\text{AuCl}(\text{PPh}_3)]\text{-Ti}[\text{PF}_6]$, and can be recovered unchanged from concentrated sulphuric acid. These observations also show that, in the case of ruthenium, the two pyrazolate bridging ligands have a marked tendency to hold two adjacent metal centres in a chemically extremely stable configuration, as occurs with rhodium and iridium.^{1,2}

Substitution of Carbonyl Ligands.—It has been reported that the complexes $[\text{Ru}_2(\mu\text{-RCO}_2)_2(\text{CO})_6]$ ($\text{R} = \text{alkyl}^{8,10}$ or aryl^9)

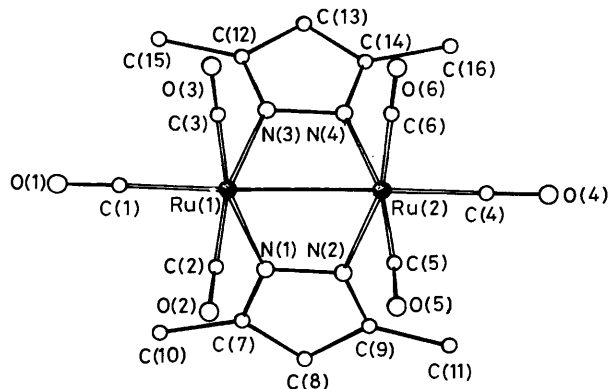
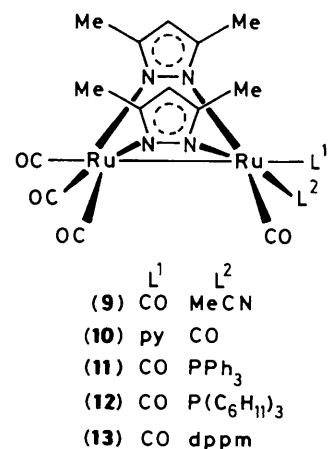

Figure 1. Perspective view of $[\text{Ru}_2(\mu\text{-dmpz})_2(\text{CO})_6]$ (1) with the atomic numbering scheme

react with a variety of nitrogen- and phosphorus-donor ligands (L') to give the tetracarbonyls $[\text{Ru}_2(\mu\text{-RCO}_2)_2(\text{CO})_4\text{L}'_2]$, the substituted CO ligands being those *trans* to the metal-metal bond. However, complex (1) does not react with an excess of acetonitrile or pyridine at room temperature, but gives the monosubstituted products (9) or (10) at 56°C . With an excess of triphenylphosphine, tricyclohexylphosphine, or bis(diphenylphosphino)methane (dppm) the reactions take place at room temperature but only monosubstituted products are formed [(11)—(13)]. Curiously enough, substitution takes place at the position *trans* to the metal-metal bond only in the pyridine derivative (10), as indicated by its ^1H n.m.r. spectrum (Table 2), which shows two singlets for the four dmpz methyls and one singlet for both C-H protons of the pyrazolate rings, revealing that the molecule has a mirror plane that contains the metal-metal bond. The i.r. spectra of complexes (9) and (11)—(13) display the same pattern of CO absorptions, as expected for compounds with the same structure. Their ^1H n.m.r. spectra show four singlets for the dmpz methyls and two singlets for the C-H protons of the pyrazolate rings, indicating that the molecules do not have any symmetry and therefore the substitution has occurred *cis* to the metal-metal bond. The $^{31}\text{P}\{^1\text{H}\}$ n.m.r. spectrum of complex (13) (Table 2) clearly shows that the dppm ligand is unidentate (two doublets with $\Delta\delta = 70$ p.p.m. and $J = 40$ Hz).²⁹

We have attempted the reaction of complex (1) with different phosphines at 60°C , in a 1:1 Ru:P ratio, but were unable to isolate any well defined products.

X-Ray structures of Complexes (1) and (5).—The structure of complex (1) is depicted in Figure 1; selected bond distances and

Table 3. Selected bond distances (Å) and angles (°) in complex (1)

| | | | |
|------------------|-----------|------------------|-----------|
| Ru(1)–Ru(2) | 2.705(2) | C(7)–C(8) | 1.367(19) |
| Ru(1)–N(1) | 2.071(9) | C(8)–C(9) | 1.383(18) |
| Ru(1)–N(3) | 2.090(13) | N(2)–C(9) | 1.332(14) |
| Ru(2)–N(2) | 2.081(8) | N(3)–C(12) | 1.332(18) |
| Ru(2)–N(4) | 2.088(11) | C(12)–C(13) | 1.43(2) |
| Ru(1)–C(1) | 1.928(15) | C(13)–C(14) | 1.38(2) |
| Ru(1)–C(2) | 1.872(17) | N(4)–C(14) | 1.32(2) |
| Ru(1)–C(3) | 1.839(15) | C(1)–O(1) | 1.14(2) |
| Ru(2)–C(4) | 1.975(18) | C(2)–O(2) | 1.15(2) |
| Ru(2)–C(5) | 1.837(15) | C(3)–O(3) | 1.17(2) |
| Ru(2)–C(6) | 1.868(14) | C(4)–O(4) | 1.12(2) |
| N(1)–N(2) | 1.367(13) | C(5)–O(5) | 1.16(2) |
| N(3)–N(4) | 1.368(14) | C(6)–O(6) | 1.13(2) |
| N(1)–C(7) | 1.341(14) | | |
| N(1)–Ru(1)–N(3) | 85.4(4) | N(4)–Ru(2)–C(4) | 98.6(6) |
| N(1)–Ru(1)–Ru(2) | 71.4(3) | N(4)–Ru(2)–Ru(1) | 71.5(3) |
| N(1)–Ru(1)–C(1) | 97.7(6) | C(6)–Ru(2)–Ru(1) | 96.3(5) |
| N(1)–Ru(1)–C(2) | 91.3(5) | Ru(1)–N(1)–N(2) | 108.8(7) |
| C(1)–Ru(1)–N(3) | 96.8(6) | C(7)–N(1)–N(2) | 105.6(9) |
| C(1)–Ru(1)–C(2) | 96.9(8) | Ru(1)–N(1)–C(7) | 145.4(8) |
| C(2)–Ru(1)–C(3) | 90.7(7) | Ru(2)–N(2)–N(1) | 108.7(6) |
| C(1)–Ru(1)–C(3) | 93.4(7) | C(9)–N(2)–N(1) | 109.5(9) |
| C(2)–Ru(1)–Ru(2) | 95.2(4) | Ru(2)–N(2)–C(9) | 141.8(8) |
| C(3)–Ru(1)–N(3) | 90.1(6) | Ru(1)–N(3)–N(4) | 109.0(8) |
| C(3)–Ru(1)–Ru(2) | 97.1(6) | C(12)–N(3)–N(4) | 110.5(10) |
| N(3)–Ru(1)–Ru(2) | 71.0(3) | Ru(1)–N(3)–C(12) | 140.5(9) |
| N(2)–Ru(2)–Ru(1) | 71.0(3) | Ru(2)–N(4)–N(3) | 108.2(8) |
| N(2)–Ru(2)–C(4) | 97.0(6) | C(14)–N(4)–N(3) | 107.7(10) |
| N(2)–Ru(2)–C(5) | 89.4(5) | Ru(2)–N(4)–C(14) | 143.9(9) |
| N(2)–Ru(2)–N(4) | 85.0(4) | Ru(1)–C(1)–O(1) | 179(1) |
| C(4)–Ru(2)–C(5) | 93.9(7) | Ru(1)–C(2)–O(2) | 178(1) |
| C(5)–Ru(2)–Ru(1) | 95.3(4) | Ru(1)–C(3)–O(3) | 174(1) |
| C(4)–Ru(2)–C(6) | 95.3(7) | Ru(2)–C(4)–O(4) | 177(2) |
| C(5)–Ru(2)–C(6) | 93.7(7) | Ru(2)–C(5)–O(5) | 179(1) |
| N(4)–Ru(2)–C(6) | 89.3(6) | Ru(2)–C(6)–O(6) | 177(1) |

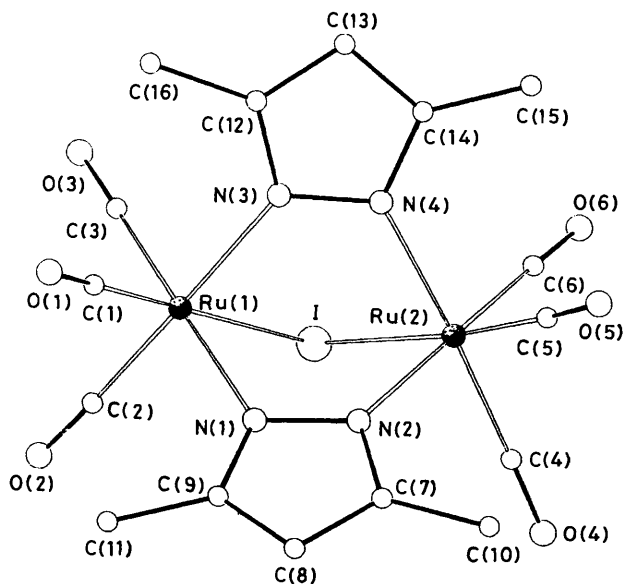
**Figure 2.** Perspective view of $[\text{Ru}_2(\mu\text{-I})(\mu\text{-dmpz})_2(\text{CO})_6]^+$ (5) with the atomic numbering scheme

angles are given in Table 3. The two Ru atoms are doubly bridged by two dmpz ligands co-ordinating through their nitrogen atoms. The Ru–Ru distance, 2.705(2) Å, is consistent with a metal–metal bond. Each Ru atom is in an octahedral

Table 4. Selected bond distances (Å) and angles (°) in complex (5)

| | | | |
|-----------------|-----------|------------------|-----------|
| Ru(1)–I | 2.699(2) | N(1)–C(9) | 1.336(14) |
| Ru(1)–N(1) | 2.102(9) | C(8)–C(9) | 1.359(17) |
| Ru(1)–N(3) | 2.124(9) | C(7)–C(8) | 1.383(15) |
| Ru(1)–C(1) | 1.928(13) | N(2)–C(7) | 1.355(15) |
| Ru(1)–C(2) | 1.904(13) | N(3)–C(12) | 1.333(13) |
| Ru(1)–C(3) | 1.910(13) | C(12)–C(13) | 1.386(17) |
| Ru(2)–I | 2.707(2) | C(13)–C(14) | 1.389(16) |
| Ru(2)–N(2) | 2.105(8) | N(4)–C(14) | 1.348(14) |
| Ru(2)–N(4) | 2.101(8) | C(1)–O(1) | 1.104(16) |
| Ru(2)–C(4) | 1.908(12) | C(2)–O(2) | 1.141(16) |
| Ru(2)–C(5) | 1.909(15) | C(3)–O(3) | 1.133(16) |
| Ru(2)–C(6) | 1.893(12) | C(4)–O(4) | 1.130(16) |
| N(1)–N(2) | 1.383(11) | C(5)–O(5) | 1.114(19) |
| N(3)–N(4) | 1.362(11) | C(6)–O(6) | 1.133(15) |
| I–Ru(1)–N(1) | 87.6(3) | C(4)–Ru(2)–C(6) | 89.5(5) |
| I–Ru(1)–N(3) | 88.6(2) | C(5)–Ru(2)–C(6) | 95.1(5) |
| I–Ru(1)–C(3) | 89.5(4) | Ru(1)–I–Ru(2) | 84.5(1) |
| I–Ru(1)–C(2) | 87.7(4) | Ru(1)–N(1)–N(2) | 122.0(6) |
| N(1)–Ru(1)–N(3) | 91.2(4) | Ru(1)–N(1)–C(9) | 130.4(8) |
| N(1)–Ru(1)–C(1) | 88.1(4) | N(2)–N(1)–C(9) | 107.6(9) |
| N(1)–Ru(1)–C(2) | 93.1(4) | Ru(2)–N(2)–N(1) | 121.7(6) |
| N(3)–Ru(1)–C(1) | 88.4(4) | Ru(2)–N(2)–C(7) | 129.3(8) |
| N(3)–Ru(1)–C(3) | 88.9(4) | N(1)–N(2)–C(7) | 107.2(8) |
| C(1)–Ru(1)–C(3) | 94.8(5) | Ru(1)–N(3)–N(4) | 121.8(6) |
| C(2)–Ru(1)–C(3) | 86.6(5) | Ru(1)–N(3)–C(12) | 128.2(8) |
| C(1)–Ru(1)–C(2) | 95.7(5) | N(4)–N(3)–C(12) | 108.4(9) |
| I–Ru(2)–N(2) | 90.7(3) | Ru(2)–N(4)–N(3) | 122.6(6) |
| I–Ru(2)–N(4) | 86.1(3) | Ru(2)–N(4)–C(14) | 128.5(8) |
| I–Ru(2)–C(4) | 90.7(4) | N(3)–N(4)–C(14) | 108.9(9) |
| I–Ru(2)–C(6) | 84.6(4) | Ru(1)–C(1)–O(1) | 176(1) |
| N(2)–Ru(2)–N(4) | 90.5(4) | Ru(1)–C(2)–O(2) | 176(1) |
| N(2)–Ru(2)–C(4) | 87.9(5) | Ru(1)–C(3)–O(3) | 176(1) |
| N(2)–Ru(2)–C(5) | 89.9(5) | Ru(2)–C(4)–O(4) | 178(1) |
| N(4)–Ru(2)–C(5) | 88.5(5) | Ru(2)–C(5)–O(5) | 177(1) |
| N(4)–Ru(2)–C(6) | 91.8(4) | Ru(2)–C(6)–O(6) | 176(1) |
| C(4)–Ru(2)–C(5) | 94.8(6) | | |

arrangement determined by three carbon atoms from terminal carbonyls, two nitrogen atoms from two bridging ligands, and the other Ru atom. The Ru–Ru distance in (1) is comparable with those found in other binuclear $\text{Ru}^{\text{I}}\text{-Ru}^{\text{I}}$ complexes with bridging ligands, such as $[\{\text{Ru}(\mu\text{-Br})(\text{CO})_2(\text{PBU}^{\text{t}}_3)_2\}_2]$, 2.672(2) Å,^{12c} and $[\{\text{Ru}(\mu\text{-C}_3\text{H}_7\text{CO}_2)(\text{CO})_2(\text{PBU}^{\text{t}}_3)_2\}_2]$, 2.728(1) Å,^{12e} but longer than in $[\{\text{Ru}(\mu\text{-Cl})(\text{CO})_2[\text{PBU}^{\text{t}}_2(\text{C}_6\text{H}_4\text{Me-}p)]_2\}_2]$, 2.632 Å.^{12a} The two pyrazolate rings are nearly orthogonal, the dihedral angle between the mean planes through them being 94.4(4)°. The Ru_2N_4 framework adopts a boat conformation, with both Ru atoms 1.38 Å above the mean plane through the four nitrogen atoms and a dihedral angle of 91.3(2)° between the mean planes through Ru(1), Ru(2), N(1), N(2) and Ru(1), Ru(2), N(3), N(4).

The structure of complex (5) consists of binuclear cationic complexes and tri-iodide anions. The cation is represented in Figure 2 and selected bond distances and angles are given in Table 4. The cation can be derived from the binuclear complex (1) by inserting an iodine atom into the Ru–Ru bond, so that the two Ru atoms are joined by three bridges, an iodide and two pyrazolates. The dihedral angles involving these bridges are approximately 120°, and the dihedral angle between the two pyrazolate bridges is 128.6(4)° and those formed by the iodide bridge and the pyrazolate rings are 116.8(3) [with N(1) and N(2)] and 112.2(3)° [with N(3) and N(4)]. The insertion of the iodine atom into the Ru–Ru bond with formation of an almost symmetrical bridge [Ru(1)–I 2.699(2) and Ru(2)–I 2.707(2) Å] determines a lengthening of the Ru–Ru separation to 3.636(2) Å, clearly indicative of no metal–metal interaction. The co-

ordination around the Ru atoms is octahedral and involves three carbon atoms from terminal carbonyls, two nitrogen atoms from two bridging dmpz ligands, and the iodine atom. The Ru–N bond distances, in the range 2.101(8)–2.124(9) Å, are only slightly longer than the ones found in (1), 2.071(9)–2.090(13) Å, with the metals in a lower oxidation state.

The dimensions of the I_3^- anion are quite regular [I(2)–I(3) 2.941(2), I(3)–I(4) 2.887(2) Å, I(2)–I(3)–I(4) 178.5(1)°].

Experimental

Solvents were dried and distilled prior to use. Unless otherwise stated all reactions were carried out under nitrogen. The compound $RuCl_3 \cdot nH_2O$ (Johnson Matthey) and all ligands were used as purchased commercially. Elemental analyses were carried out on a Perkin-Elmer 240-C microanalyzer. I.r. spectra were recorded on a Perkin-Elmer 783 spectrophotometer and were calibrated against a sharp peak (1601.4 cm^{-1}) of polystyrene film. N.m.r. spectra were recorded on a Varian XL-200 spectrometer at 20 °C with $SiMe_4$ (internal, 1H) or 85% H_3PO_4 (external, ^{31}P) as references ($\delta = 0$ p.p.m.). Mass spectra were obtained by using the f.a.b. technique on a Kratos MS-80 spectrometer, using xenon as bombarding gas. Molecular weights were measured in chloroform on a Knauer osmometer at 20 °C. Since the methods used to synthesize some compounds were very similar, only typical preparations are given.

Preparation of $[Ru_2(\mu-L)_2(CO)_6][L = dmpz$ (1), pz (2), 3-methylpyrazolate (3), or indazolone (4)].—Carbon monoxide was bubbled through a solution of $RuCl_3 \cdot nH_2O$ (1.5 g, 5.37 mmol) in 2-methoxyethanol (60 cm^3) at reflux temperature. When the colour of the solution turned pale yellow (ca. 2.5 h), 3,5-dimethylpyrazole (551 mg, 5.37 mmol) and granular zinc (4 g) (previously purified with dilute HCl, washed with distilled water, and dried with acetone) were added. The mixture was stirred at reflux temperature, while maintaining a slow stream of carbon monoxide. After 2–3 h the heating was stopped, and the brown suspension was decanted from the unreacted zinc. Addition of water (200 cm^3) resulted in precipitation of a pale yellow solid, which was filtered off, washed with water, dried, and extracted with dichloromethane (5 cm^3). This solution was chromatographed on a silica-gel column (10 × 3 cm). n-Hexane afforded two bands: the first one, yellow, was discarded; the second, colourless moved very slowly with n-hexane and the eluant was changed to n-hexane–dichloromethane (1:1). Removal of the solvent afforded complex (1) as white crystals (1.376 g, 85%).

Complexes (2)–(4) were prepared similarly in 56, 81, and 74% yields, respectively.

Preparation of $[Ru_2(\mu-I)(\mu-L)_2(CO)_6]I_3$ [$L = dmpz$ (5), or pz (6)].—Iodine (56.7 mg, 0.26 mmol) and complex (1) (48.5 mg, 0.086 mmol) were stirred in dichloromethane (10 cm^3) for 2 h. n-Hexane (10 cm^3) was added to the red-brown solution and the volume was reduced to ca. 5 cm^3 . The precipitate was filtered off, washed with diethyl ether, and dried to give (5) as a brown powder (97 mg, 97%). Recrystallization by vapour diffusion of diethyl ether into a dichloromethane solution of (5) afforded the compound as dark green needles.

Complex (6) was prepared similarly from complex (2) in 90% yield.

Preparation of $[Ru_2I_2(\mu-dmpz)_2(CO)_6]$ (7).—Iodine (25.8 mg, 0.102 mmol) and complex (1) (57 mg, 0.102 mmol) were stirred in dichloromethane (10 cm^3) for 17 h. The orange solution was evaporated to dryness and the residue was washed

with n-hexane, filtered off, and dried to afford (7) as an orange powder (33 mg, 40%).

Preparation of $[Ru_2I_2(\mu-pz)_2(CO)_6]$ (8).—Iodine (50.3 mg, 0.198 mmol) and complex (2) (100 mg, 0.198 mmol) were stirred in dichloromethane (10 cm^3) for 5 h, giving a white precipitate and an orange solution. The white solid was filtered off, washed with n-hexane, and identified as the isomer (8a) or (8b) (35 mg, 23%). The orange solution was concentrated to ca. 1 cm^3 and n-hexane was added (5 cm^3). The solid was filtered off, washed with n-hexane, and identified by 1H spectroscopy as a 1:4 mixture of the isomer (8a) or (8b) with (8c) (99 mg, 66%).

Reaction of Complex (5) with $[IrCl(CO)(PPh_3)_2]$.—Complex (5) (20 mg, 0.017 mmol) and $[IrCl(CO)(PPh_3)_2]$ (13 mg, 0.017 mmol) were stirred in dichloromethane (20 cm^3). The i.r. spectrum of the solution showed that after 5 min both starting materials had been transformed into complex (7) and $[IrI_2Cl(CO)(PPh_3)_2][v(CO) 2065\text{ cm}^{-1}]$.

Preparation of $[Ru_2(\mu-dmpz)_2(CO)_5(NCMe)]$ (9).—An excess of acetonitrile (ca. 0.2 cm^3) was added to a solution of complex (1) (80 mg, 0.134 mmol) in acetone (25 cm^3). The solution was stirred at 56 °C for 20 h. Evaporation to dryness afforded a pale yellow solid which was washed with hexane and dried (60 mg, 73%).

Preparation of $[Ru_2(\mu-dmpz)_2(CO)_5(py)]$ (10).—An excess of pyridine (ca. 1.2 cm^3) was added to a solution of complex (1) (100 mg, 0.178 mmol) in tetrahydrofuran (25 cm^3). The solution was stirred at 56 °C for 7 h, and then evaporated to dryness. The pale yellow solid was washed with hexane and dried (74 mg, 67%).

Preparation of $[Ru_2(\mu-dmpz)_2(CO)_5(PR_3)]$ [$PR_3 = PPh_3$ (11), $P(C_6H_{11})_3$ (12), or $dppm$ (13)].—A solution of triphenylphosphine (47 mg, 0.179 mmol) in dichloromethane (10 cm^3) was added to a solution of complex (1) (100 mg, 0.178 mmol) in the same solvent (10 cm^3). The resulting pale yellow solution was stirred for 6 h and then evaporated to dryness to give an oil. Addition of methanol (2 cm^3) with vigorous stirring (30 min) afforded a pale yellow precipitate which was filtered off, washed with methanol, and dried (85 mg, 60%).

Complexes (12) and (13) were prepared similarly from the appropriate phosphines in 50 and 53% yields, respectively. The same complexes were obtained using an excess of the phosphine ligands.

Crystal Structure Determinations of Complexes (1) and (5).—*Crystal data for (1).* $C_{16}H_{14}N_4O_6Ru_2$, $M = 560.45$, monoclinic, space group $P2_1/n$, $a = 15.388(7)$, $b = 10.497(5)$, $c = 13.706(5)$ Å, $\beta = 110.32(2)^\circ$, $U = 2076(2)$ Å³ (by least-squares refinement of the θ values of 25 accurately measured reflections), $Z = 4$, $\lambda = 0.71069$ Å, $D_c = 1.793\text{ g cm}^{-3}$, $F(000) = 1096$, $\mu(\text{Mo-K}\alpha) = 14.64\text{ cm}^{-1}$. A crystal of approximate dimensions $0.22 \times 0.25 \times 0.30$ mm was used for the structure analysis. No absorption correction was made.

Crystal data for (5). $C_{16}H_{14}I_4N_4O_6Ru_2$, $M = 1068.07$, triclinic, space group $P\bar{1}$, $a = 10.970(5)$, $b = 12.393(6)$, $c = 10.522(6)$ Å, $\alpha = 98.22(2)$, $\beta = 103.94(3)$, $\gamma = 74.29(2)^\circ$, $U = 1332(1)$ Å³ (by least-squares refinement of the θ values of 29 accurately measured reflections), $Z = 2$, $\lambda = 0.71069$ Å, $D_c = 2.663\text{ g cm}^{-3}$, $F(000) = 972$, $\mu(\text{Mo-K}\alpha) = 57.38\text{ cm}^{-1}$. A crystal of approximate dimensions $0.15 \times 0.20 \times 0.23$ mm was used for the structure analysis. A correction for absorption³⁰ was applied (maximum and minimum transmission factors were 1.267 and 0.748 respectively) using the program ABSORB.³¹

Table 5. Fractional atomic co-ordinates ($\times 10^4$) with estimated standard deviations (e.s.d.s) in parentheses for the non-hydrogen atoms of complex (1)

| Atom | x | y | z | Atom | x | y | z |
|-------|-----------|-----------|-----------|-------|-----------|-----------|-----------|
| Ru(1) | 2 267(1) | 4 044(1) | 5 533(1) | C(3) | 1 427(11) | 3 081(15) | 4 517(14) |
| Ru(2) | 2 193(1) | 6 139(1) | 4 358(1) | C(4) | 2 497(12) | 7 679(16) | 3 713(12) |
| O(1) | 2 939(9) | 1 777(12) | 7 019(12) | C(5) | 1 267(9) | 6 925(11) | 4 692(10) |
| O(2) | 742(7) | 4 896(9) | 6 298(8) | C(6) | 1 379(10) | 5 462(16) | 3 117(12) |
| O(3) | 859(10) | 2 564(14) | 3 839(12) | C(7) | 3 771(9) | 5 673(12) | 7 388(10) |
| O(4) | 2 636(10) | 8 554(13) | 3 325(10) | C(8) | 4 063(9) | 6 910(14) | 7 448(11) |
| O(5) | 689(7) | 7 437(9) | 4 905(8) | C(9) | 3 623(8) | 7 390(11) | 6 459(10) |
| O(6) | 860(8) | 5 064(13) | 2 379(9) | C(10) | 3 989(11) | 4 681(17) | 8 279(11) |
| N(1) | 3 174(7) | 5 393(8) | 6 437(7) | C(11) | 3 663(10) | 8 688(11) | 6 038(12) |
| N(2) | 3 102(6) | 6 478(8) | 5 862(7) | C(12) | 3 850(9) | 3 024(13) | 4 677(11) |
| N(3) | 3 226(7) | 3 847(9) | 4 774(8) | C(13) | 4 280(10) | 3 625(14) | 4 024(12) |
| N(4) | 3 233(7) | 4 941(9) | 4 235(7) | C(14) | 3 856(9) | 4 802(14) | 3 785(10) |
| C(1) | 2 689(13) | 2 616(12) | 6 462(15) | C(15) | 4 011(13) | 1 747(13) | 5 138(16) |
| C(2) | 1 333(10) | 4 579(12) | 6 024(11) | C(16) | 4 056(12) | 5 830(15) | 3 122(13) |

Table 6. Fractional atomic co-ordinates ($\times 10^4$) with e.s.d.s in parentheses for the non-hydrogen atoms of complex (5)

| Atom | x | y | z | Atom | x | y | z |
|-------|------------|----------|-----------|-------|------------|-----------|------------|
| Ru(1) | 461(1) | 2 320(1) | 8 967(1) | C(1) | 1 154(11) | 1 359(10) | 10 393(12) |
| Ru(2) | -2 744(1) | 2 726(1) | 6 833(1) | C(2) | 1 148(11) | 3 544(10) | 9 861(12) |
| I(1) | -725(1) | 3 629(1) | 6 963(1) | C(3) | 1 976(11) | 1 848(9) | 8 240(11) |
| I(2) | -2 387(1) | 5 963(1) | 4 384(1) | C(4) | -3 896(13) | 4 188(11) | 6 828(13) |
| I(3) | -3 491(1) | 7 425(1) | 6 497(1) | C(5) | -4 055(12) | 1 952(11) | 6 731(11) |
| I(4) | -4 591(1) | 8 810(1) | 8 591(1) | C(6) | -2 939(11) | 2 695(10) | 4 992(11) |
| O(1) | 1 486(9) | 798(7) | 11 199(9) | C(7) | -3 337(11) | 3 267(10) | 9 666(11) |
| O(2) | 1 610(9) | 4 264(7) | 10 344(9) | C(8) | -2 705(11) | 3 543(10) | 10 927(11) |
| O(3) | 2 861(8) | 1 633(7) | 7 790(9) | C(9) | -1 424(11) | 3 274(8) | 10 903(10) |
| O(4) | -4 545(10) | 5 068(9) | 6 849(13) | C(10) | -4 787(12) | 3 401(14) | 9 185(14) |
| O(5) | -4 779(10) | 1 458(8) | 6 679(10) | C(11) | -340(12) | 3 416(10) | 12 055(11) |
| O(6) | -3 045(10) | 2 732(8) | 3 900(9) | C(12) | 418(12) | -83(9) | 7 586(12) |
| N(1) | -1 250(8) | 2 894(7) | 9 690(8) | C(13) | -281(13) | -580(10) | 6 491(12) |
| N(2) | -2 454(8) | 2 893(8) | 8 896(8) | C(14) | -1 439(13) | 213(10) | 6 114(11) |
| N(3) | -236(8) | 978(7) | 7 801(8) | C(15) | -2 506(16) | 32(12) | 5 028(14) |
| N(4) | -1 379(9) | 1 164(7) | 6 902(8) | C(16) | 1 721(13) | -629(10) | 8 415(15) |

Data collection and processing. Siemens AED diffractometer, θ - 2θ scan mode, using niobium-filtered Mo- K_α radiation; all the reflections with θ in the ranges 3–25 (1) and 3–27° (5) were measured. Of 3 773 (1) and 5 696 (5) independent reflections, 1 987 (1) and 3 348 (5), having $I \geq 2\sigma(I)$, were considered observed and used in the analysis.

Structure solutions and refinements. Patterson and Fourier methods; full-matrix least squares with anisotropic thermal parameters in the last cycles for all the non-hydrogen atoms. The hydrogen atoms were placed at their geometrically calculated positions and introduced in the final structure-factor calculations. The weighting scheme used in the last cycles of refinement was $w = k[\sigma^2(F_o) + gF_o^2]^{-1}$ with $k = 0.687$ (1) and 0.557 (5), $g = 0.004$ (1) and 0.012 (5). Final R and R' values were 0.056 and 0.069 (1), and 0.043 and 0.063 (5). The SHELX system of computer programs was used.³² Atomic scattering factors, corrected for anomalous dispersion of Ru and I, were taken from ref. 33. All calculations were performed on the CRAY X-MP/12 computer of the Centro di Calcolo Elettronico Interuniversitario dell'Italia Nord-orientale, Bologna and on the GOULD 32/77 computer of the Centro di Studio per la Strutturistica Diffattometrica del CNR, Parma. Final atomic co-ordinates for the non-hydrogen atoms are given in Tables 5 (1) and 6 (5).

Additional material available from the Cambridge Crystallographic Data Centre comprises H-atom co-ordinates, thermal parameters, and remaining bond distances and angles.

Acknowledgements

We thank the CSIC-CNR Joint Programme (8 + 1987/88) and Comision Asesora de Investigacion Cientifica y Tecnica for support, the Spanish Ministry of Education for a fellowship (to J. A. C.), and Dr. D. W. Bruce and P. Ashton (University of Sheffield) for f.a.b. mass spectra.

References

- 1 A. L. Bandini, G. Banditelli, F. Bonati, G. Minghetti, F. Demartin, and M. Manassero, *J. Organomet. Chem.*, 1984, **269**, 91 and refs. therein; J. L. Atwood, K. A. Beveridge, G. W. Bushnell, K. R. Dixon, D. T. Eadie, S. R. Stobart, and M. J. Zaworotko, *Inorg. Chem.*, 1984, **23**, 4050; G. W. Bushnell, D. E. Fjeldstedt, S. R. Stobart, M. J. Zaworotko, S. A. R. Knox, and K. A. McPherson, *Organometallics*, 1985, **4**, 1107.
- 2 (a) R. Usón, L. A. Oro, M. A. Ciriano, M. T. Pinillos, A. Tiripicchio, and M. Tiripicchio-Camellini, *J. Organomet. Chem.*, 1981, **205**, 247; (b) R. Usón, L. A. Oro, M. A. Ciriano, M. T. Pinillos, and J. A. Cabeza, *ibid.*, **221**, 249; (c) L. A. Oro, D. Carmona, M. P. Lamata, M. C. Aprea, C. Foces-Foces, F. H. Cano, and P. M. Maitlis, *J. Chem. Soc., Dalton Trans.*, 1984, 1823; (d) L. A. Oro, D. Carmona, P. L. Pérez, M. Esteban, A. Tiripicchio, and M. Tiripicchio-Camellini, *ibid.*, 1985, 973; (e) L. A. Oro, D. Carmona, M. P. Lamata, C. Foces-Foces, and F. H. Cano, *Inorg. Chim. Acta*, 1985, **97**, 19; (f) L. A. Oro, M. T. Pinillos, A. Tiripicchio, and M. Tiripicchio-Camellini, *ibid.*, **99**, L13; (g) L. A. Oro, D. Carmona, M. P. Puebla, M. P. Lamata, C. Foces-Foces, and F. H. Cano, *ibid.*, 1986, **112**, L11.
- 3 E. O. Fischer and A. Vogler, *Z. Naturforsch., Teil B*, 1962, **17**, 421.

- 4 'Comprehensive Organometallic Chemistry,' eds. G. Wilkinson, F. G. A. Stone, and E. W. Abel, Pergamon, London, 1982, vol. 4, pp. 651—966; E. A. Seddon and K. R. Seddon, 'The Chemistry of Ruthenium,' Elsevier, Amsterdam, 1984.
- 5 N. C. Thomas, *Coord. Chem. Rev.*, 1986, **70**, 121; S. C. Tripathi, S. C. Srivastava, R. P. Mani, and A. K. Shrimal, *Inorg. Chim. Acta*, 1975, **15**, 249.
- 6 A. P. Humphries and S. A. R. Knox, *J. Chem. Soc., Dalton Trans.*, 1975, 1710.
- 7 S. A. R. Knox, J. W. Koepke, M. A. Andrews, and H. D. Kaesz, *J. Am. Chem. Soc.*, 1975, **97**, 3942.
- 8 G. R. Cooks, B. F. G. Johnson, J. Lewis, J. G. Williams, and G. Gamlen, *J. Chem. Soc. A*, 1969, 2761.
- 9 M. Rotem, I. Goldberg, U. Shmueli, and Y. Shvo, *J. Organomet. Chem.*, 1986, **314**, 185.
- 10 (a) M. Bianchi, G. Menchi, F. Francalanci, and F. Piacenti, *J. Organomet. Chem.*, 1980, **188**, 109; (b) M. Bianchi, P. Ferdiani, U. Matteoli, G. Menchi, F. Piacenti, and G. Petrucci, *ibid.*, 1983, **259**, 207.
- 11 M. I. Bruce, G. Shaw, and F. G. A. Stone, *J. Chem. Soc., Dalton Trans.*, 1972, 2094; A. Colombie, G. Lavigne, and J. J. Bonnet, *ibid.*, 1986, 899; M. Cooke, M. Green, and D. Kirkpatrick, *J. Chem. Soc. A*, 1968, 1507; G. R. Crooks, B. F. G. Johnson, J. Lewis, and I. G. Williams, *ibid.*, 1969, 797; R. P. Rosen, G. L. Geoffroy, C. Bueno, M. R. Churchill, and R. B. Ortega, *J. Organomet. Chem.*, 1983, **254**, 89; M. I. Bruce, M. Z. Iqbal, and F. G. A. Stone, *ibid.*, 1971, **31**, 275; E. Sappa, O. Gambino, and G. Cetini, *ibid.*, 1972, **35**, 375; A. J. P. Domingos, B. F. G. Johnson, J. Lewis, and G. M. Sheldrick, *J. Chem. Soc., Chem. Commun.*, 1973, 912; B. E. Job, R. A. N. McLean, and D. T. Thompson, *Chem. Commun.*, 1966, 895; E. Roland and H. Varenkamp, *Chem. Ber.*, 1980, **113**, 1799; R. E. Dessy, A. L. Rheingold, and G. D. Howard, *J. Am. Chem. Soc.*, 1972, **94**, 746; D. F. Jones, P. H. Dixneuf, A. Benoit, and J. Y. Marquille, *Inorg. Chem.*, 1983, **22**, 29; S. Jeannin, Y. Jeannin, and G. Lavigne, *Transition Met. Chem. (Weinheim, Ger.)*, 1976, **1**, 186.
- 12 (a) R. Mason, K. M. Thomas, D. F. Gill, and B. L. Shaw, *J. Organomet. Chem.*, 1972, **40**, C67; (b) D. F. Gill, B. E. Mann, and B. L. Shaw, *J. Chem. Soc., Dalton Trans.*, 1973, 311; (c) H. Schumann, J. Opitz, and J. Pickart, *Chem. Ber.*, 1980, **113**, 1385; (d) H. Schumann and J. Opitz, *ibid.*, p. 989; (e) H. Schumann, J. Opitz, and J. Pickart, *J. Organomet. Chem.*, 1977, **128**, 253.
- 13 B. R. James and R. W. Wang, *J. Chem. Soc., Chem. Commun.*, 1977, 550; J. D. McClure, R. Owyang, and L. H. Slaugh, *J. Organomet. Chem.*, 1968, **12**, P8; U. Matteoli, G. Menchi, P. Ferdiani, M. Bianchi, and F. Piacenti, *ibid.*, 1985, **285**, 281.
- 14 G. L. Rempel, W. K. Teo, B. R. James, and D. V. Plackett, *Adv. Chem. Ser.*, 1974, **132**, 166.
- 15 M. Rotem and Y. Shvo, *Organometallics*, 1983, **2**, 1689.
- 16 L. A. Oro, M. P. Garcia, D. Carmona, C. Foces-Foces, and F. H. Cano, *Inorg. Chim. Acta*, 1985, **96**, L21; M. P. Garcia, A. Portilla, L. A. Oro, C. Foces-Foces, and F. H. Cano, *J. Organomet. Chem.*, 1987, **322**, 111.
- 17 T. V. Ashworth, D. C. Liles, and F. Singleton, *J. Chem. Soc., Chem. Commun.*, 1984, 1317; *Inorg. Chim. Acta*, 1985, **98**, L65.
- 18 S. Trofimenko, *Prog. Inorg. Chem.*, 1986, **34**, 115 and refs. therein.
- 19 J. A. Cabeza, C. Landázuri, L. A. Oro, A. Tiripicchio, and M. Tiripicchio-Camellini, *J. Organomet. Chem.*, 1987, **322**, C16.
- 20 Ref. 2a, p. 693; J. Chatt, B. L. Shaw, and A. E. Field, *J. Chem. Soc.*, 1964, 3466.
- 21 A. Mantovani and S. Cenini, *Inorg. Synth.*, 1976, **16**, 47.
- 22 J. G. Bullitt and F. A. Cotton, *Inorg. Chim. Acta*, 1971, **5**, 406.
- 23 M. I. Bruce, M. G. Humphrey, M. R. Snow, E. R. T. Tiekink, and R. C. Wallis, *J. Organomet. Chem.*, 1986, **314**, 311.
- 24 H. Schumann and J. Opitz, *J. Organomet. Chem.*, 1980, **186**, 91.
- 25 J. C. T. R. Burckett-St Laurent, J. S. Field, R. J. Haines, and M. McMahon, *J. Organomet. Chem.*, 1978, **153**, C19.
- 26 D. A. Brown, A. R. Manning, and D. J. Thornhill, *Chem. Commun.*, 1969, 338; R. J. Haines and A. L. du Preez, *J. Chem. Soc. A*, 1970, 2341.
- 27 R. J. Haines and A. L. du Preez, *J. Chem. Soc., Dalton Trans.*, 1972, 944.
- 28 V. Riera, M. A. Ruiz, A. Tiripicchio, and M. Tiripicchio-Camellini, *J. Organomet. Chem.*, 1986, **308**, C19.
- 29 R. Usón, J. Forníés, P. Espinet, R. Navarro, and C. Fortuño, *J. Chem. Soc., Dalton Trans.*, 1987, 2077.
- 30 N. Walker and D. Stuart, *Acta Crystallogr., Sect. A*, 1983, **39**, 158.
- 31 F. Uguzzoli, *Comput. Chem.*, 1987, **11**, 109.
- 32 G. M. Sheldrick, SHELX program for crystal structure determination, University of Cambridge, 1976.
- 33 'International Tables for X-Ray Crystallography,' Kynoch Press, Birmingham, 1974, vol. 4.

Received 5th May 1988; Paper 8/01765D